

S 40.1

Smontagomme Automatico
Automatic tyre changer

femas®

S 40.1

MADE IN ITALY

DATI TECNICI - TECHNICAL DATA

CAPACITA' DI SERRAGGIO	CLAMPING CAPACITY	11" - 27"
SERRAGGIO ESTERNO	EXTERNAL CLAMPING	11" - 24"
SERRAGGIO INTERNO	INTERNAL CLAMPING	14" - 27"
DIAMETRO MASSIMO RUOTA	MAX. WHEEL DIAMETER	1110 mm (44")
LARGHEZZA MASSIMA RUOTA	MAX. WHEEL WIDTH	405 mm (16")
VELOCITA' DI ROTAZIONE	TURNTABLE SPEED	7/14 rpm Motoinverter 8/16 rpm 3 Ph
LIVELLO DI RUMOROSITA'	NOISE LEVEL	<70±3 dB(A)
PRESSIONE DI ESERCIZIO	WORKING PRESSURE	8 - 10 Bar (116 - 145 psi)
PESO NETTO	NET WEIGHT	Kg 325

VERSIONE/MOTORIZZAZIONI - VERSION/MOTORIZATIONS

MOTORE TRIFASE a 2 velocità 2V 0,8 - 1,1 Kw (1,1 - 1,5 HP) 8 - 16rpm comandato direttamente dal pedale.
3 - Ph foot controlled motor with 2 speeds 2V 0,8 - 1,1 Kw (1,1 - 1,5 HP) 8 - 16rpm

MOTORE MONOFASE con **Motoinverter** che permette un controllo variabile della velocità 7/14 rpm.
1 - Ph **Motoinverter** allows a variable control of motor speed 7/14 rpm.

STALLONATORE ELETTRICO INTEGRATO BREVETTATO con prestazioni del 30% in più rispetto ai tradizionali stallonatori pneumatici.
THE PATENTED INTEGRATED ELECTRICAL BEAD BREAKER improves performances up to 30% than traditional pneumatic bead breakers.

ACCESSORI STANDARD - STANDARD OPTIONS

PROTEZIONE PALETTA STALLONATORE / BEAD BLADE PROTECTION

SET DI PROTEZIONI GRIFFE / GRIPPERS PROTECTIONS SET

SPATOLA RIMUOVI PESI / TAPE -A- WEIGHT REMOVAL TOOL

ANELLO PORTA GRASSO / GREASE SUPPORT

STALLONATORE PNEUMATICO CON COMANDO MANUALE / MANUAL PNEUMATIC BEADBREAKING SYSTEM

LEVA ALZATALLONI CON PROTEZIONE IN PLASTICA / BEAD LEVEL WITH PLASTIC PROTECTION

3 + 3 PROTEZIONE UTENSILE STANDARD / 3 + 3 PROTECTIONS FOR STANDARD TOOL

DISCESA UTENSILE A MOLLA / MANUAL SPRING DESCENT

GONFIAGGIO A PISTOLA / GUN INFLATING DEVICE

ACCESSORI A RICHIESTA - UPON REQUEST OPTIONS

DOPPIO PRESSORE / DOUBLE PRESSOR DEVICE

SOLLEVATORE RUOTA / WHEEL LIFTER

RULLIERA A PAVIMENTO / FLOOR ROLLER TABLE

RULLIERA BASCULANTE / TILTING ROLLER TABLE

KIT CAMBIO RAPIDO TORRETTA / QUICK CHANGE TOOL HUB KIT

DISCESA PNEUMATICA UTENSILE / PNEUMATIC DESCENT DEVICE

GP GONFIAGGIO A PEDALE / GP FOOT CONTROLLED INFLATING UNIT

KIT GONFIAGGIO TUBELESS / TUBELESS INFLATION DEVICE KIT

UNICLAMP ADATTATORE MOTO E SCOOTER 5"-23" / UNICLAMP MOTORBIKE RIMS ADAPTER 5"-23"

Per tutti gli altri accessori consultare il catalogo a parte.
For other options, refer to separate catalogue.

SPAZIO DI LAVORO / WORKING SPACE

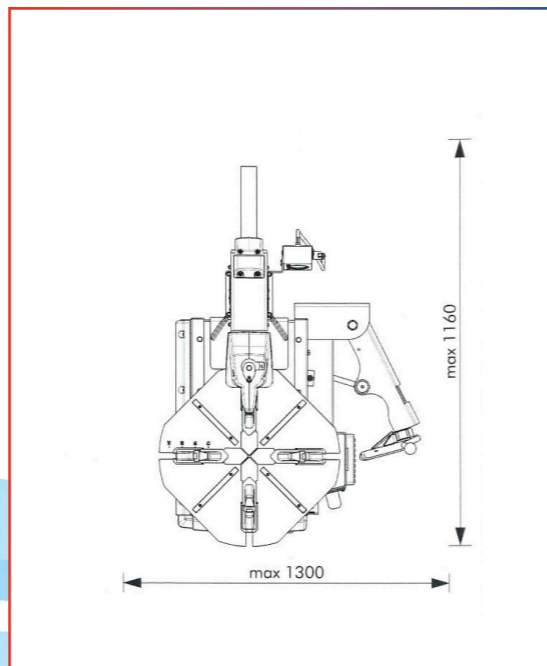

LINEE S 40

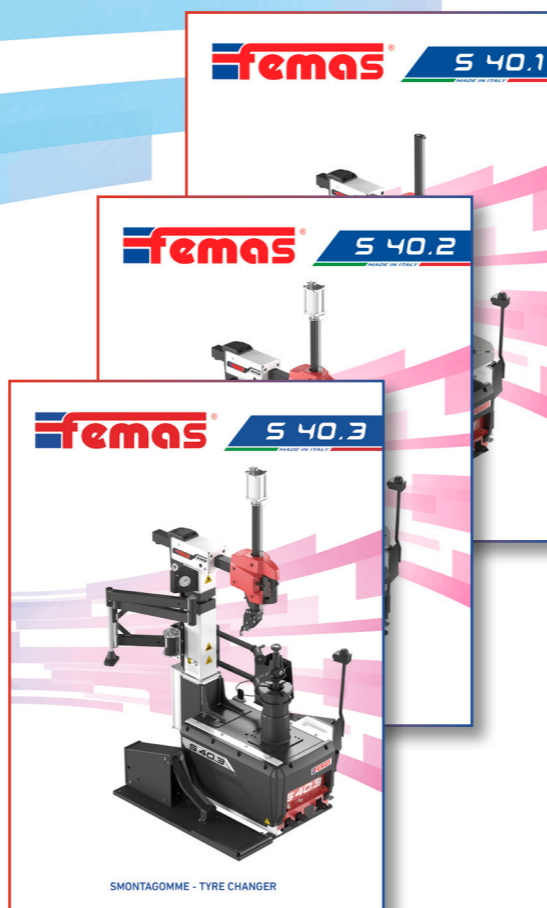

SMONTAGOMME A BANDIERA AUTOMATICA
TYRE CHANGER AUTOMATIC SWING HEAD

STANDARD

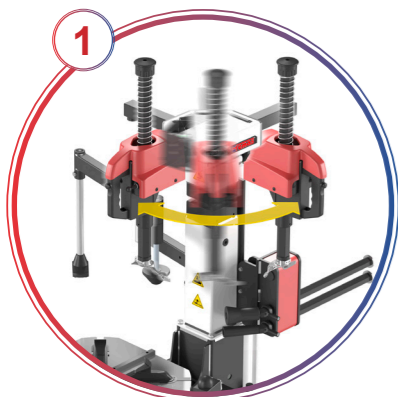

- (IT) PALO PORTA UTENSILE CON TRASLAZIONE LATERALE.
- (EN) COLUMN WITH LATERAL TRASLATION DEVICE.



- (IT) STALLONATORE PNEUMATICO CON COMANDO MANUALE (STANDARD).
STALLONATORE ELETTRICO CON COMANDO MANUALE (OPTIONAL).
- (EN) ELECTRICAL BEAD BREAKING SYSTEM (STANDARD).
MANUAL PNEUMATIC BEAD BREAKING SYSTEM (OPTION).



- (IT) PALO ORIZZONTALE con triplo sistema di bloccaggio tramite rullini di scorrimento registrabili.
- (EN) HORIZONTAL ARM is equipped with a triple locking system and with adjustable sliding rollers.



- (IT) PIATTO AUTOCENTRANTE con capacità di serraggio da 11" a 27" + versione 14" - 28" con griffe scorrevoli. (OPTIONAL).
- (EN) THE SELF-CENTRING TURNTABLE has a clamping capacity from 11" to 27" inches + version 14" - 28" with sliding jaws. (OPTION).



- (IT) PEDALIERA ERGONOMICA ESTRAIBILE.
- (EN) EXTRACTABLE FOOT CONTROL PEDAL GROUP.

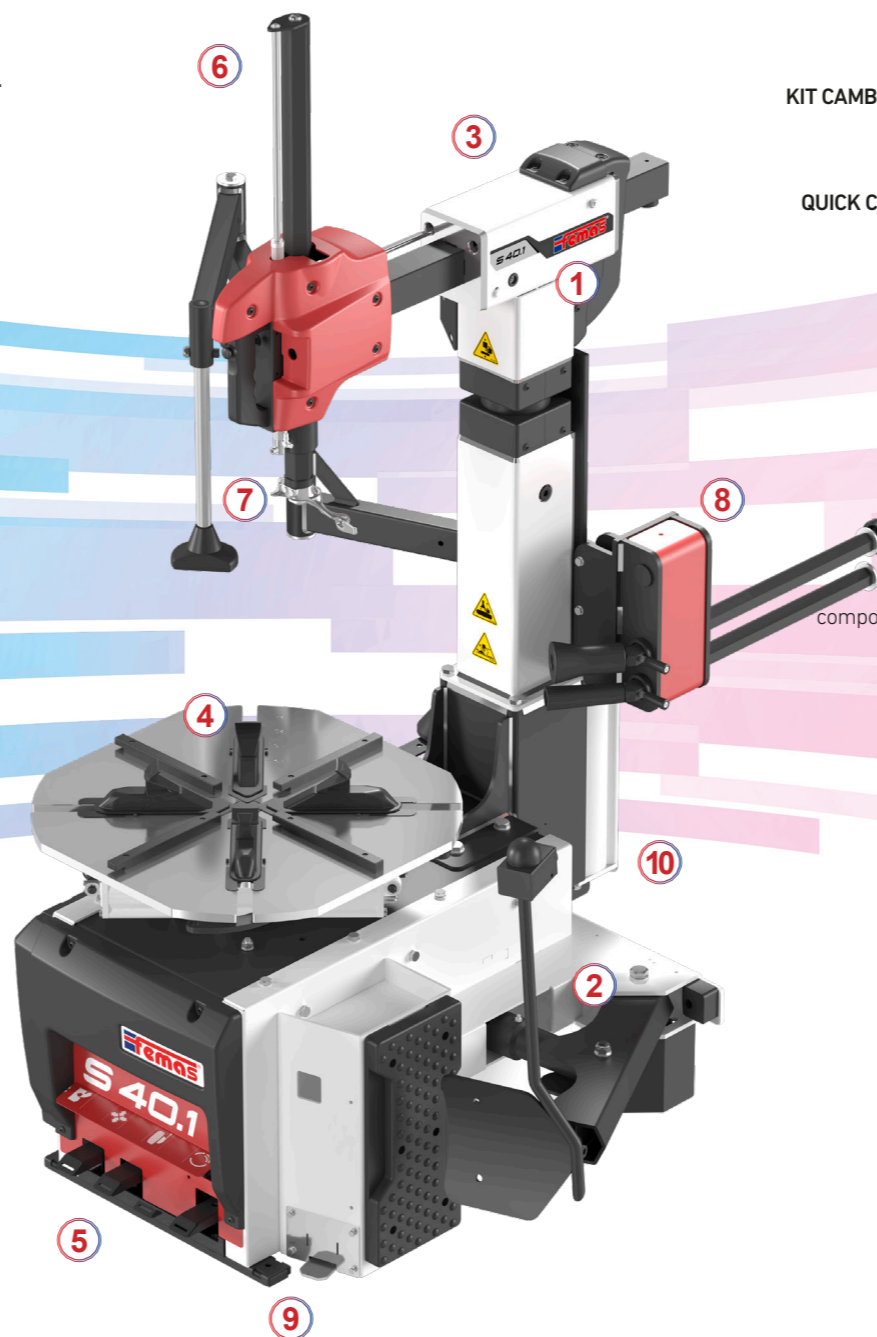

OPTIONAL

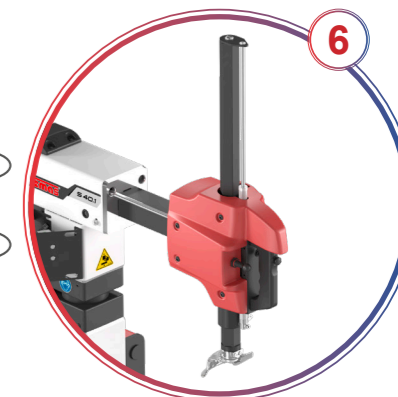

- BRACCIO PORTAUTENSILE CON CONTROLLO PNEUMATICO. (OPTIONAL). (IT)
- PNEUMATIC MOUNTING HEAD ARM. (OPTION). (EN)



- KIT CAMBIO RAPIDO TORRETTA composto da due mozzi porta torretta e da una torretta in materiale speciale. (OPTIONAL per tutte le versioni). (IT)
- QUICK CHANGE TOOL HUB KIT composed by two hubs and a mounting head in special plastic. (OPTION in all machines versions). (EN)

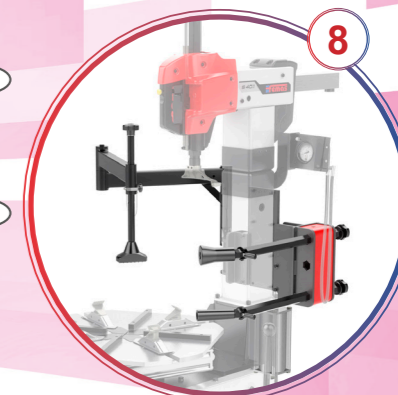

- DOPPIO PRESSORE composto da tre bracci ausiliari studiati appositamente per assistere l'operatore durante le fasi di montaggio e smontaggio. (IT)
- THE DOUBLE PRESSOR DEVICE is composed by three arms, engineered to assist the operator during mounting and demounting operations of run-flat or UHP tyres. (EN)

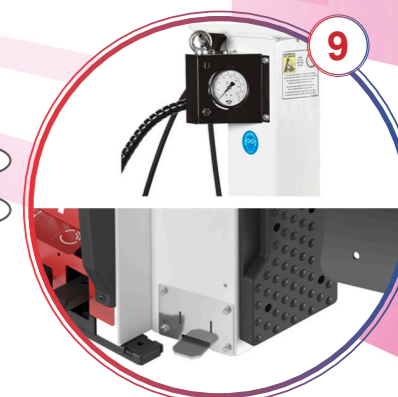

- G.P. GONFIAGGIO A PEDALE. (OPTIONAL). (IT)
- FOOT CONTROLLED INFLATING DEVICE. (OPTION). (EN)

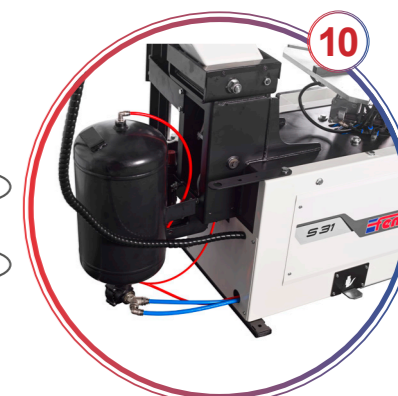

- SISTEMA GONFIA-TUBELESS INTEGRATO NELLE GRIFFE AUTOCENTRANTE. (OPTIONAL). (IT)
- TUBELESS SYSTEM INTEGRATED IN THE JAWS. (OPTION). (EN)