

# KONI

# sterfil®



MOBILE COLUMN LIFT

# ST 1075

The superior, flexible solution with a lifting capacity of 7.5 tons



**STERFIL**  
SUPERIOR SOLUTIONS

# Superior Solutions



The Stertil Group provides customised and technically advanced solutions for heavy-duty lifting requirements and loading bay equipment for customers worldwide, including the best possible service from skilled local partners. These superior solutions are conceived, developed and implemented by a team of professional specialists with unique expertise. Thanks to its quality people, its entirely in-house expertise and its international organisation, Stertil-Koni is the worldwide leader in the field of heavy-duty lifts.



## Wireless...

Our wireless mobile column lifts provide the superior solution for situations where the lifts need to be moved regularly. Thanks to the innovative ID key, 32 columns, each with a lifting capacity of 7.5 tons, can be used simultaneously.

In most cases, the special deep cycle batteries only need to be recharged every two weeks. No time is wasted connecting up cables and the mechanic has maximum access to the vehicle, without any tripping hazard.

## ... or cabled, it's up to you

If you predominantly work in a fixed location, the cabled mobile ST 1075 column lift could be the best solution. This set up offers the possibility to connect up to 32 columns into a single configuration. The cabled version also has a lifting capacity of 7.5 tons per column. Extra strong drive over cables are optionally available for the cabled column lifts. All interconnection cables are equipped with heavy-duty plugs at both ends.

# Wireless mobile column lifts

## with **ebright Smart Control System**



TOUCH SCREEN



WIRELESS



Both the wireless and the cabled column lifts are equipped with a control panel on each individual column. With the push of a button, the columns can be operated individually, in pairs or simultaneously as a complete set. Each column can be operated at any given location.

### Full-colour touch screen control

The revolutionary **ebright Smart Control System** combines intuitive **ease of use** with maximum visual information about the lifting process. The main advantages:

- Touch screen control, works even when wearing gloves
- User-configured options, such as choice of language, safety warnings and scheduled maintenance
- Full-colour 7" screen, graphically highly attractive
- All relevant information available at a glance
- Customizable ID-Key to prevent unauthorized operation
- Wireless Mesh network for optimal connectivity



## Reliable hydraulic technology

- Long usable life of the column with minimal repair and maintenance due to reduced friction
- Stringent testing before leaving factory
- Manual lowering in case of a power outage
- Maximum protection of the cylinder and seal against damage

## Adjustable lowering speed

Do you want to lower the vehicle more slowly, so that you have more control when lowering onto axle stands? This is easily done at the high resolution touch screen.

## Simple recharging

The wireless mobile columns can be simply charged via a 230 V wall socket. The cabled mobile column lifts operate from a 400 V supply with other voltages available.

## Fast lifting and lowering

The ST 1075 only takes 75 seconds to reach its maximum lifting height of 1,850 mm. This makes it one of the fastest mobile column lifts in the world.

## Easy to move

Stertil-Koni mobile column lifts really are 'mobile'. Thanks to the synthetic wheels and the hydraulic pallet truck mechanism with patented overload protection, the column is easy to move.

## Safe workspace

We have designed as an extra safety feature a large working space between the column and the vehicle. For example, if a problem with the air suspension occurs, the vehicle should not come into contact with the column.



## Unique synchronisation

The synchronisation system is activated at a height difference of just 15 mm. This ensures safe and smooth lifting and lowering cycles, even in the event of an extremely uneven load distribution.

## Lifetime guarantee

The innovative synthetic runner wheels within the column come with a lifetime parts guarantee.

## Adjustable pick-up forks

ST 1075 mobile column lifts have a fork length of 350 mm and are therefore perfect for picking up a variety of vehicles even vehicles with super single tyres in a safe and secure manner.

# Well thought out in all aspects



**32  
MAX**

MAX 32 LINKED  
COLUMNS



ADJUSTABLE  
LOWERING SPEED



OVERLOAD  
PROTECTION



UNIQUE  
SYNCHRONISATION  
SYSTEM

## Wireless

The control panel on each column is equipped with ebright Smart Control System having a clear high resolution touch screen. Additional information, such as the charging status of the battery, the exact lifting height and the number of columns in the setup can be read on this display. Thanks to the patented Multi Master System the columns can be setup in any order.

## Cabled

These columns are powered via a power outlet in the workshop. The columns communicate with each other via interconnecting cables. Optional extra strong drive-over interconnection cables are available to provide protection against damage.



○ High resolution 7" touch screen

○ Intuitive controls



## ebright Features

SMART CONTROL SYSTEM

- High resolution 7" touch screen
- Owner/User configurable system with user ID key
  - Individual user settings for setting language and units
  - Protection against unauthorized use due to personalised ID key
- Maintenance notifications
- Visual display of maximum programmable lifting height if set
- Warning & failure information
- Operation manual on-screen available if required
- Tracking of specific operations and information codes
- Intuitive controls with actual data about the lift:
  - Indication for Single, All or Pair operation mode
  - Information about how many columns are in the set (up to 32 columns)
  - Actual lifting height displayed
  - Lowering speed can be manually adjusted on the touch screen
  - Battery status information
  - Customizable ID-Key to prevent unauthorized operation
- Wireless Mesh network with continuous active channel search offering optimal connectivity

# Everything under control



| Overview of ST 1075 models  | ebright wireless<br>ST 1075FWA | ebright cabled<br>ST 1075FSA |
|---|--------------------------------|------------------------------|
| ebright Smart Control System with a control box on each individual column                                       | ●                              | ●                            |
| Touch screen with important information about the system e.g. lifting height, operation mode                    | ●                              | ●                            |
| Wireless Mesh network with continuous active channel search offering optimal connectivity                       | ●                              |                              |
| These columns utilise a power outlet in the workshop and communicate with each other via interconnecting cables |                                | ●                            |
| Adjustable lowering speed for slow or normal lowering   | ●                              | ●                            |
| Hydraulic pallet truck lifting mechanism with patented overload protection                                      | ●                              | ●                            |
| 350 mm adjustable fork, suitable for super single tyres   | ●                              | ●                            |
| Fixed synthetic wheels that reduce the pressure on the floor  | ●                              | ●                            |

## Technical specifications

- Lifting capacity: 7,500 kg
- Lift system: hydraulic lifting system with microprocessor-controlled synchronisation
- Lifting height: maximum 1,850 mm, automatic stop at the highest position
- Lifting time: 75 seconds
- Motor rating: 2.2 / 3.0 kW per column (Cabled / Wireless)
- Weight: 595 kg per column (Wireless)
- Column height: 2,465 mm

## Highest safety requirements

- ANSI/ALI-ALCTV certified (USA).
- CSA certified (Canada).
- CE certified (Europe).
- Independent mechanical locking system engages at 460 mm above floor level. Locking pawl engaged by gravity. The locking system is always active, even when the column is turned off.
- Locking profile with locking increments of just 35 mm.
- Synchronisation between the mobile lifting columns starts at a height difference of 15 mm.
- Each mobile lifting column is equipped with a safety valve that monitors the system for sudden pressure loss – i.e. caused by leakage - during the entire lifting process.
- Automatic overload protection.
- Low voltage control panel.
- Each column is equipped with an emergency stop
- Each individual mobile lifting column is tested prior to leaving the factory.
- Splash-proof electrical system (IP 65).

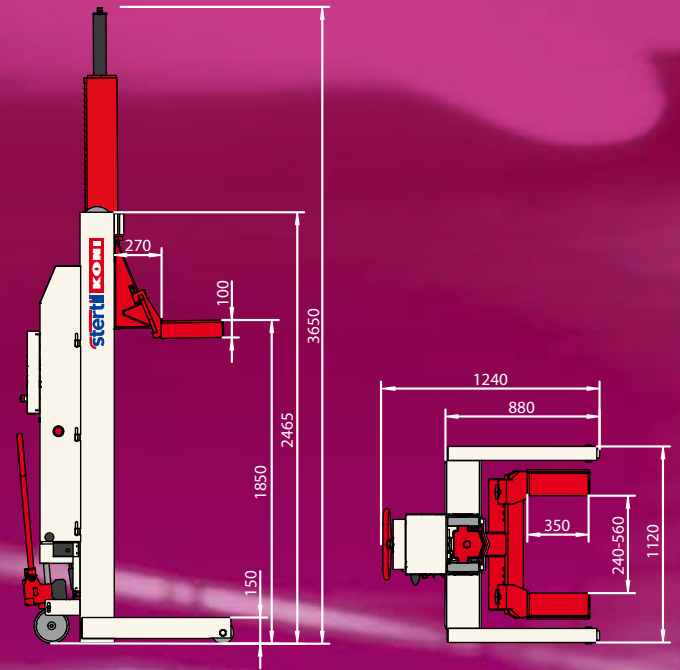

## Accessories & options

Stertil-Koni offers an extensive package of options and accessories to tailor your lift to your specific needs.

Optional products available include:

- Lighting set.
- Forklift adapter set.
- Various crossbeams for lifting trailers and special vehicles.
- Fork and base frame extension sets.
- Forklift pockets for easy lifting and transportation of the column.

## For more information

For more or specific information about the ST 1075, or any of Stertil-Koni's other top products, please do not hesitate to contact us. We will be pleased to assist you.



Stertil B.V.  
P.O.Box 23  
9288 ZG Kootstertille  
The Netherlands  
Tel. +31 (0)512 334444  
www.sterilkoni.com  
info@sterilkoni.nl  
f Stertil-Koni  
@Stertil